

- NOTES: UNLESS OTHERWISE SPECIFIED.  
 1. MATL: ALUMINUM ALLOY.  
 2. REMOVE ALL BURRS & SHARP EDGES.  
 3. FINISH:

REVISIONS				
LTR	DESCRIPTION	DATE	DRWN BY	APPROVED
A	RELEASE TO PRODUCTION	07/09/2002	JAG	JAG

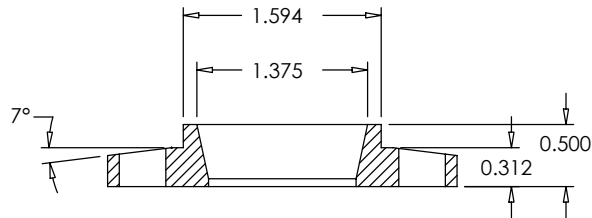
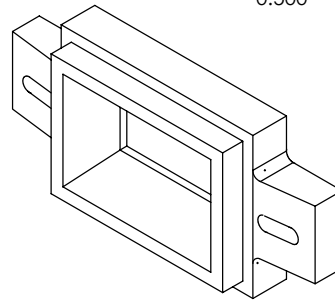
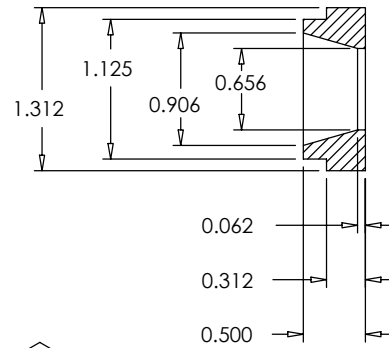
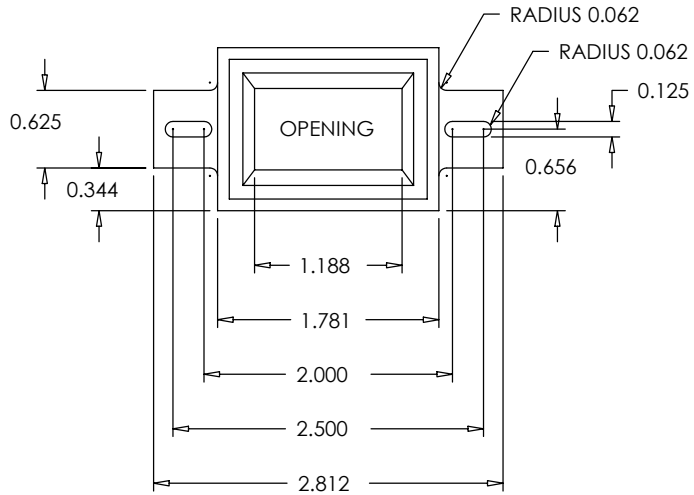

## SMALL LOGIC DISPLAY BOX

SIZE	UNITS	DRAWING NO.	REV.
A	INCHES		A
SCALE	FULL	DRAWN JAG	07/09/2002 SHEET OF 1